



Global supplier of **engineered systems** for major vehicle manufacturers in the **agriculture sector**









INVESTOR PRESENTATION

October 2023



COFLE GROUP

Key Highlights

KEY POINTS	DESCRIPTION
<p>1</p> <p>Growth</p> 	<ul style="list-style-type: none">• Secular trends driving increased total addressable market• Global Farm Tractors Market Forecast to 2031 estimated growing with +5,5% CAGR 2021-2031¹ 
<p>2</p> <p>Global Presence</p> 	<ul style="list-style-type: none">• We are where our customers (Tier 1 players) are• Presence in Europe, Turkey, Brasil and India• Intercompany Supply Chain allows an efficient raw materials supplying with a global coverage 
<p>3</p> <p>Innovation</p> 	<ul style="list-style-type: none">• Development of innovative electronic products that represent an upgrade of the control system for farm tractors and a machinery connectivity for a better use of fertilizers and weedkiller• The global precision farming market size at 9,47 \$ bn in 2022 and is expected to expand with +12,6% CAGR 2023-2030² 

COFLE GROUP: Snapshot

One global player, two divisions: OE and IAM

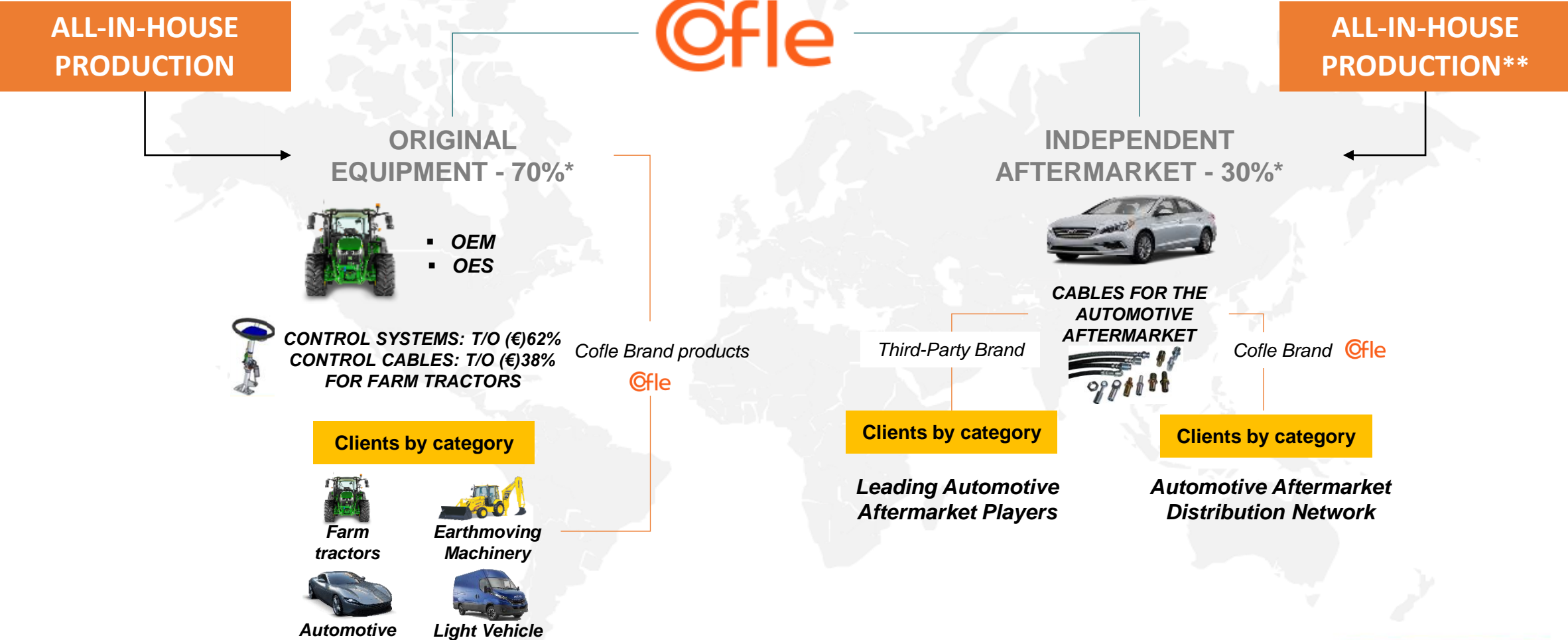

KEY MILESTONES

Group history since foundation

- **Evolution from the initial workshop setting to a more industrial one**
- At that time, about 15 people worked for the Group, which, among its many products, included clutch and brake cables for the historic cars of those years, such as the Autobianchi A112 and the unforgettable Fiat Giardinetta

- Significant boost in the Aftermarket industry - Cofle clearly part of this trend
- Set up of production activities in Turkey
- Strong commercial growth and new warehouse in Pozzo D'Adda (1996), **conceived and used exclusively for stocking and selling spare cables: starting point for the later creation of the OEM division**

- The Group aims at expanding further its products offerings, breaking into underpenetrated markets and seizing on M&A opportunities
- November 11th: Listing **EURONEXT GROWTH**

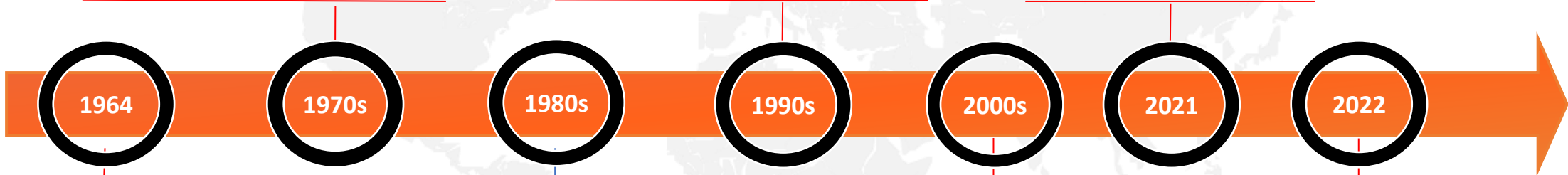

- **Bruno Barbieri founds Cofle**, introducing an innovative way in manufacturing Control Cables for the Automotive Industry
- **First production line for Original Equipment Cables (OEM) for the most important Italian brands**

- **Production of cables for the Aftermarket division**

- Founder Bruno Barbieri decides to leave Cofle's management to his son Walter
- **Established presence in Turkey, China, Brasil, India**

- **Opening of COFLE FRANCE, Beauvais**
- **ITG Turkey launched**

COFLE GROUP TODAY



PRODUCTION PLANT

6 in 4 countries



REPRESENTATIVE OFFICE

2 (France/China)



WAREHOUSE

4 in 4 countries
(Italy/Turkey/Brasil/India)



PRODUCTION CAPACITY

> 10 mln units of production capacity per year over approx. 17.000 sqm plants worldwide



ENGINEERING CENTER

2
(Italy/Turkey)



R&D CENTER

2
(Italy/Turkey)



EMPLOYEES

550+

ITALY – OE Logistic Plant TURKEY – TK 1 OE Plant TURKEY – TK 2 OE Plant

ITALY – HQ & Plant



- Plant description**
- Leased
 - 5.000 sqm
 - production capacity: 2,5 mln units



- Plant description**
- Cofle's real estate property
 - 3.500 sqm
 - Logistic services



- Plant Description**
- Leased
 - 2.000 sqm
 - Production capacity: 1,1 mln units



- Plant Description**
- Leased
 - 2.000 sqm
 - Production capacity: 1,15 mln units

ALL-IN-HOUSE PRODUCTION
Pricing power thanks to all production In-House and the delivery capacity

BRASIL – OE Plant



- Plant description**
- Leased
 - 2.000 sqm
 - Production capacity: 0,45 mln units

COFLE FRANCE
Commercial Department



- Plant description**
- Leased
 - Comm. departments IAM and OE
 - 3 Team Managers

INDIA – IAM Plant



- Plant description**
- Leased
 - 1.800 sqm
 - Production capacity: 2,5 mln units

TURKEY – IAM 2 Plant



- Plant Description**
- Leased
 - 4.000 sqm
 - Production capacity: 3,0 mln units



GROUP STRUCTURE & GOVERNANCE

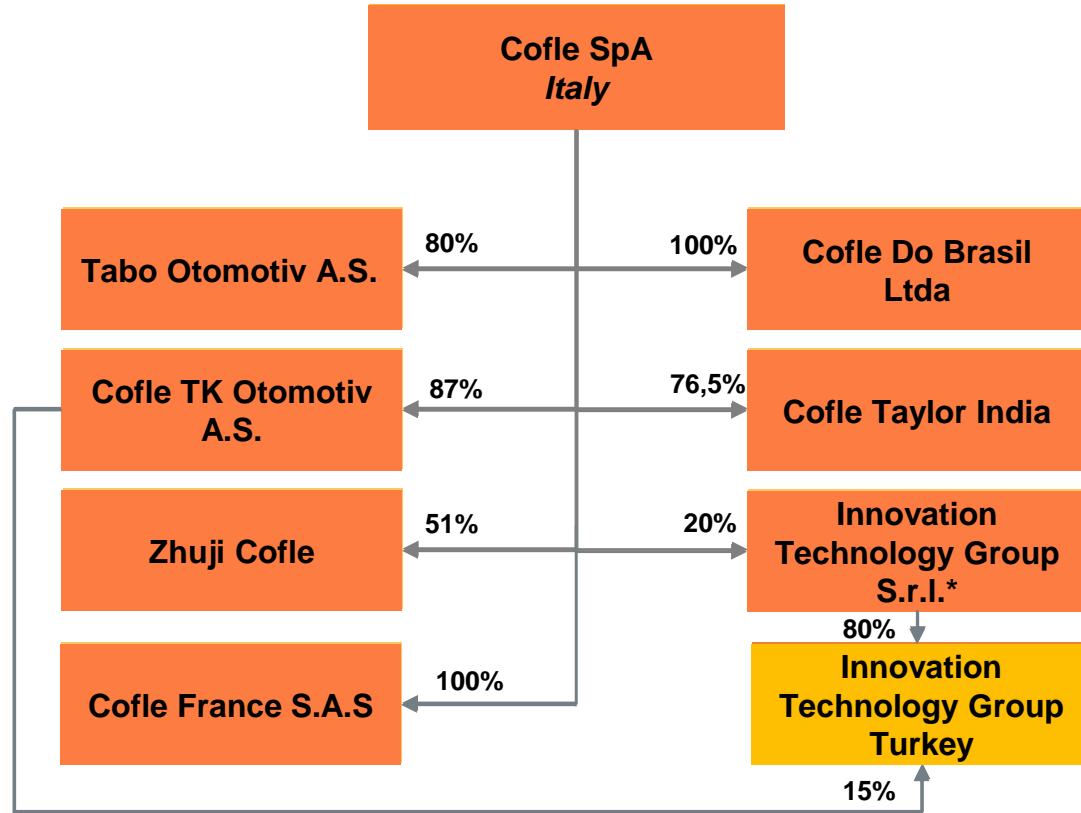

ITG shareholders: Walter Barbieri (32%) Pierangelo Margutti (~24%), Alessandro Plebani (~24%)
 ITG Turkey minority shareholders: local partner (5%)
 Cofle Taylor India Minority Shareholders - local industrial partner
 Cofle Zhuji Minority Shareholders – local industrial partner
 Tabo Otomotiv AS & Cofle TK Otomotiv AS: local industrial partners and local managers

Board of Directors

Chairman & CEO
Walter Barbieri
 Director
Alessandra Barbieri
 Director
Silvio Benedetti
 Independent Director
Enrico Mambelli
 Director
Sergio Buoncristiano

Statutory Auditors

Chairman
Giuseppe Rota
 Auditor
Arturo Carcassola
 Auditor
Ugo Palumbo
 Supplementary Auditor
Pietro Longaretti
 Supplementary Auditor
Luca Perico

Audit Firm



ORGANIZATION CHART

Experienced multinational Management Team

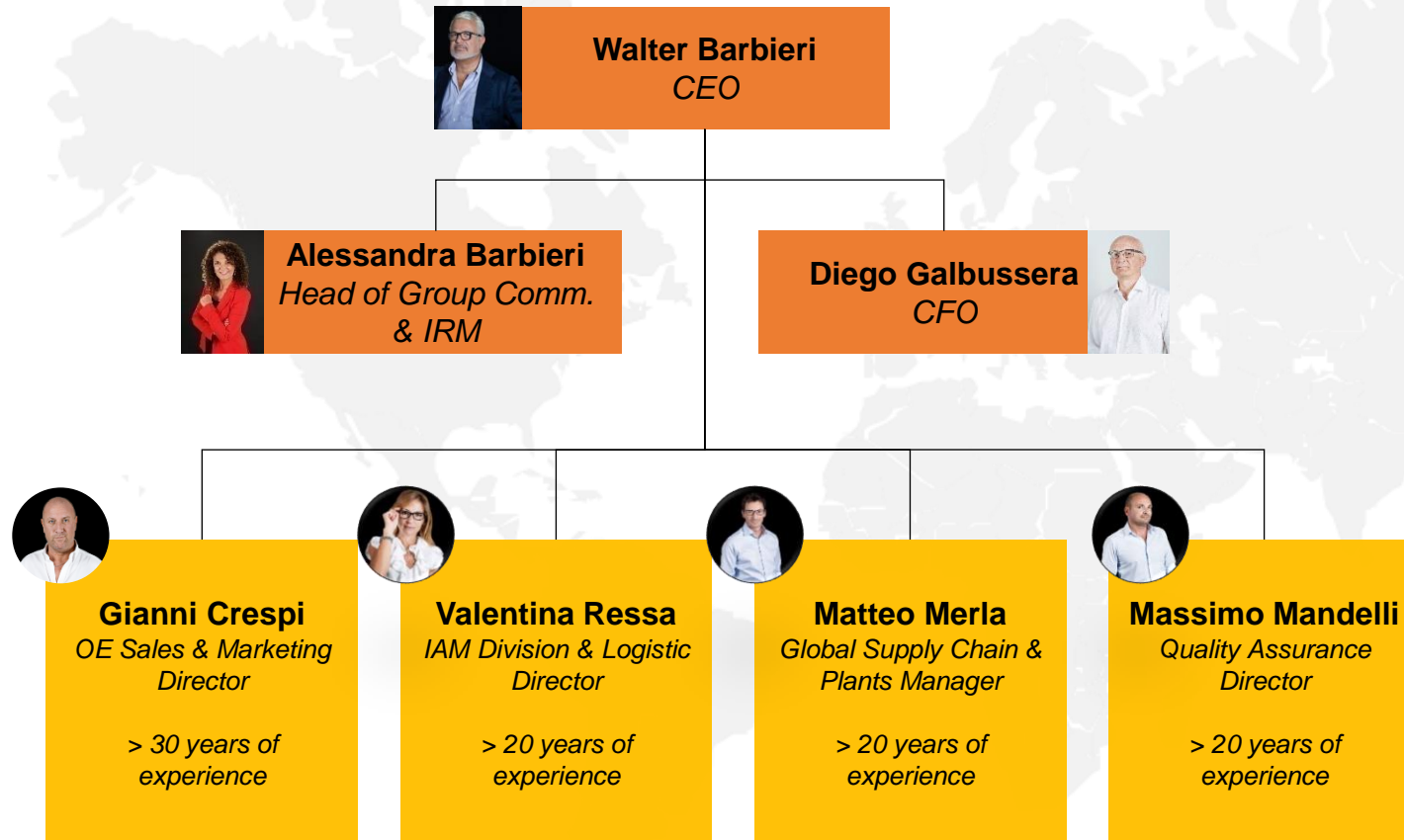

Total Workforce as of 30/06/2023	
Company	Employees
Cofle S.p.A.	148
Tabo Otomotiv	183
Cofle TK Otomotiv	212
Cofle Zhuji	1
Cofle Do Brasil	15
Cofle Taylor India	24
Cofle France	3

Total Employees 586 as of 30/06/2023

OE DIVISION

All-In-House production

Off-Road Applications

Steering Columns
Fix Hub and
Anti-Dumping
System

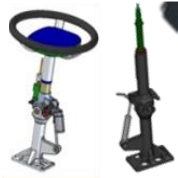

P.T.O.
Systems
Control



Brake Levers
Mother Regulation



Cables for all
applications



Gearshift Towers with
Electronics Knobs



Joysticks for Front Loader
(with push buttons
command)



Spool Valve
command

Premium Luxury Brands Applications

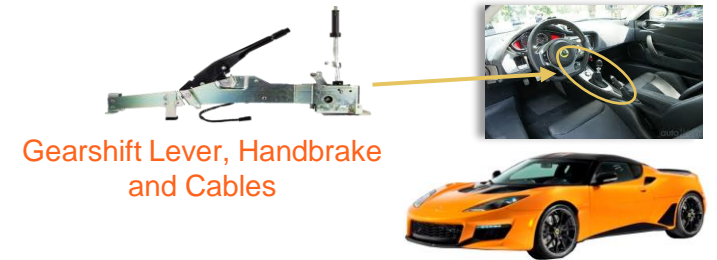

Gearshift Lever, Handbrake
and Cables



Gear Unlock DCT System cables



Front and Rear Bonnet
Cables

IAM DIVISION

All-In-House production

Control Cables



Brake Cables



Brake Hoses



Epb Systems



Epb Puller Cables

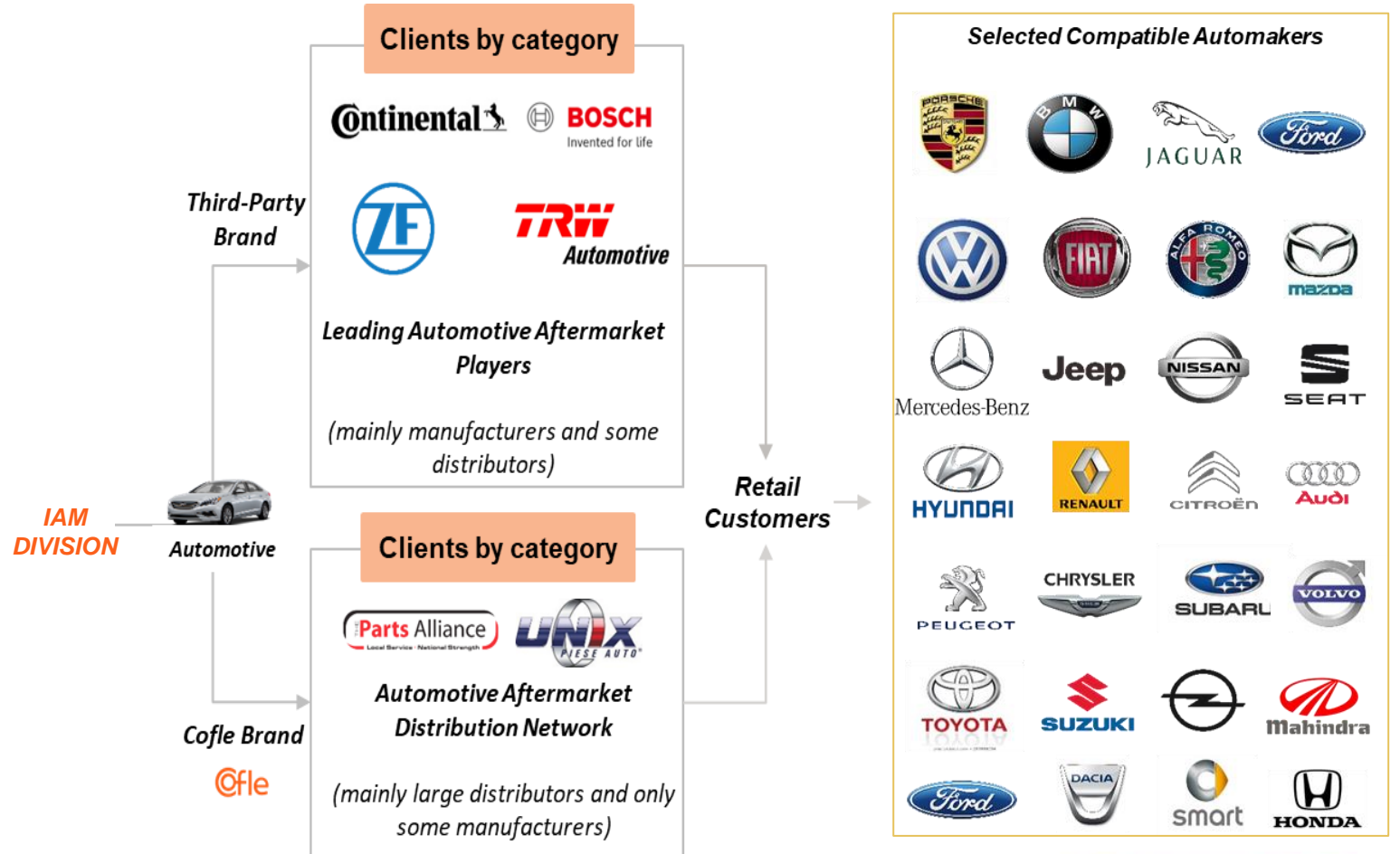

KEY INVESTMENT HIGHLIGHTS

A company ready to ride secular trends for a long-term journey

Global Growth Scenario

1 OE: Exceptionally sound path to growth on a global scale

2 IAM: Only at an early stage of international scalability

3 Strategically positioned to boost long term expansion

Excellent Positioning

4 State of Art Credentials OE

5 State of Art Credentials IAM

6 Focus on innovation to anticipate next future trends

1 OE

Exceptionally sound path to growth on a global scale catching the wave of a secular trend in population dynamics and food demand



Global Farm Tractors Market Forecast to 2031

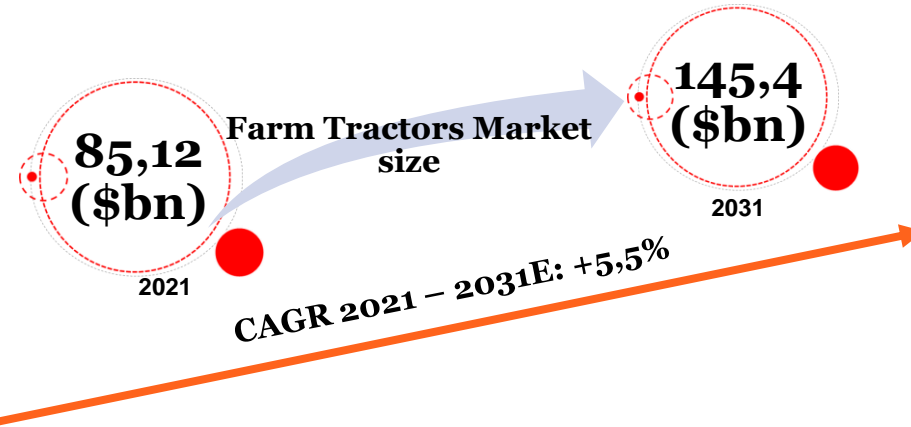

Global Farm Tractors Production 2021

~ 2,1 mln units

Global Farm Tractors Production 2022

~ 2,5 mln units

Source: Farm Tractor Market (Engine Power; Propulsion) -Global Industry Analysis, Size, Share, Growth, Trends, and Forecast, 2022-2031 - Publisher: Farm TractorsMarket ResearchGroup of HNY Research, 2022

Source: Feder Unacoma, 2023

Market Drivers

- 1 Global area harvested to cereals expected to increase by 14 Mha in the coming decade (between the base period 2020 and 2030)
- 2 Technological upgrade of farm tractors especially in developing countries, and introduction of mechatronic innovation in developed countries
- 3 PRECISION FARMING (CAGR 2023-2030 +12,6%): Environmental-friendly farm tractors upgrades imposed by regulation and policy trends all over the world
- 4 Farming support by governments to increase domestic agri production as strategic policy adopted worldwide

Planning growth in the European underpenetrated automotive Aftermarket

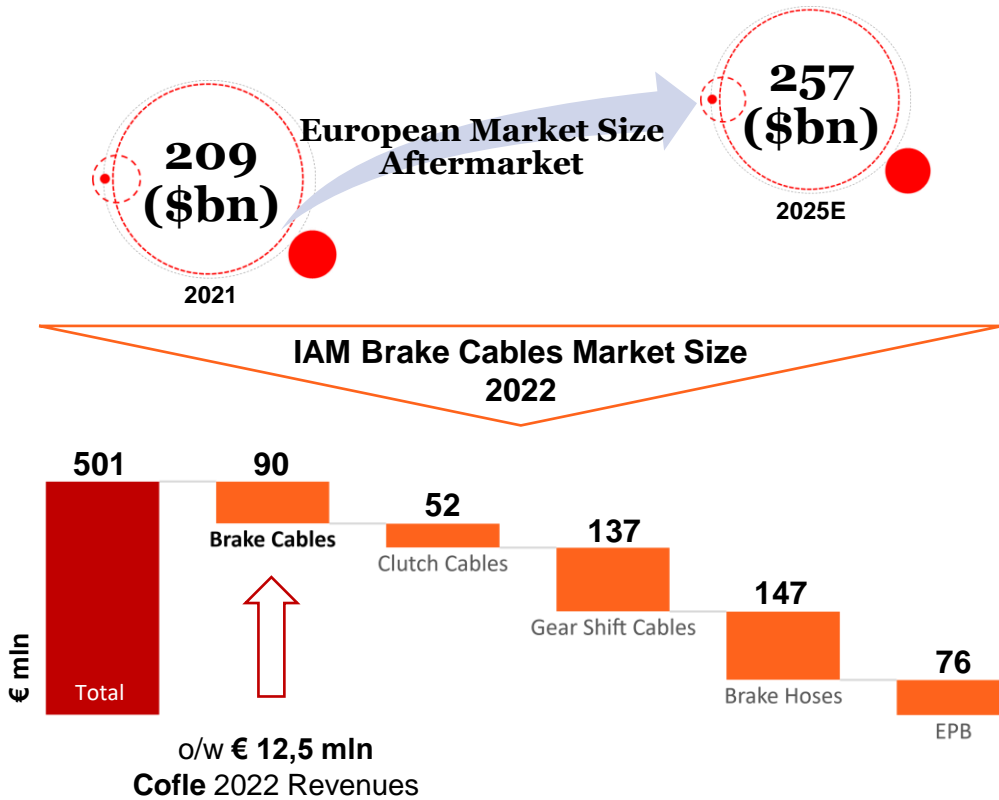

Average Age of the EU vehicle fleet

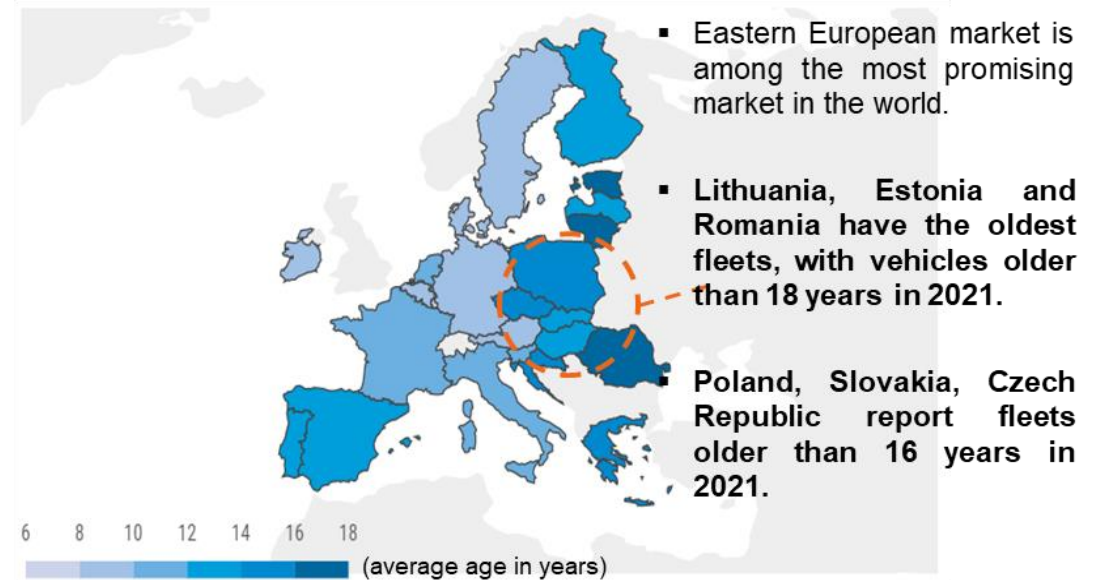

- 1 Leveraging on Italian and Turkish production plant capacity to serve the most mature western European customers
- 2 Leveraging on Italian and Indian production plant capacity to serve the most promising high-growth Eastern European market and increase market share

3

GLOBAL PRESENCE

Strategically positioned to boost long term expansion
Integrated facilities and platforms in the key areas of the world

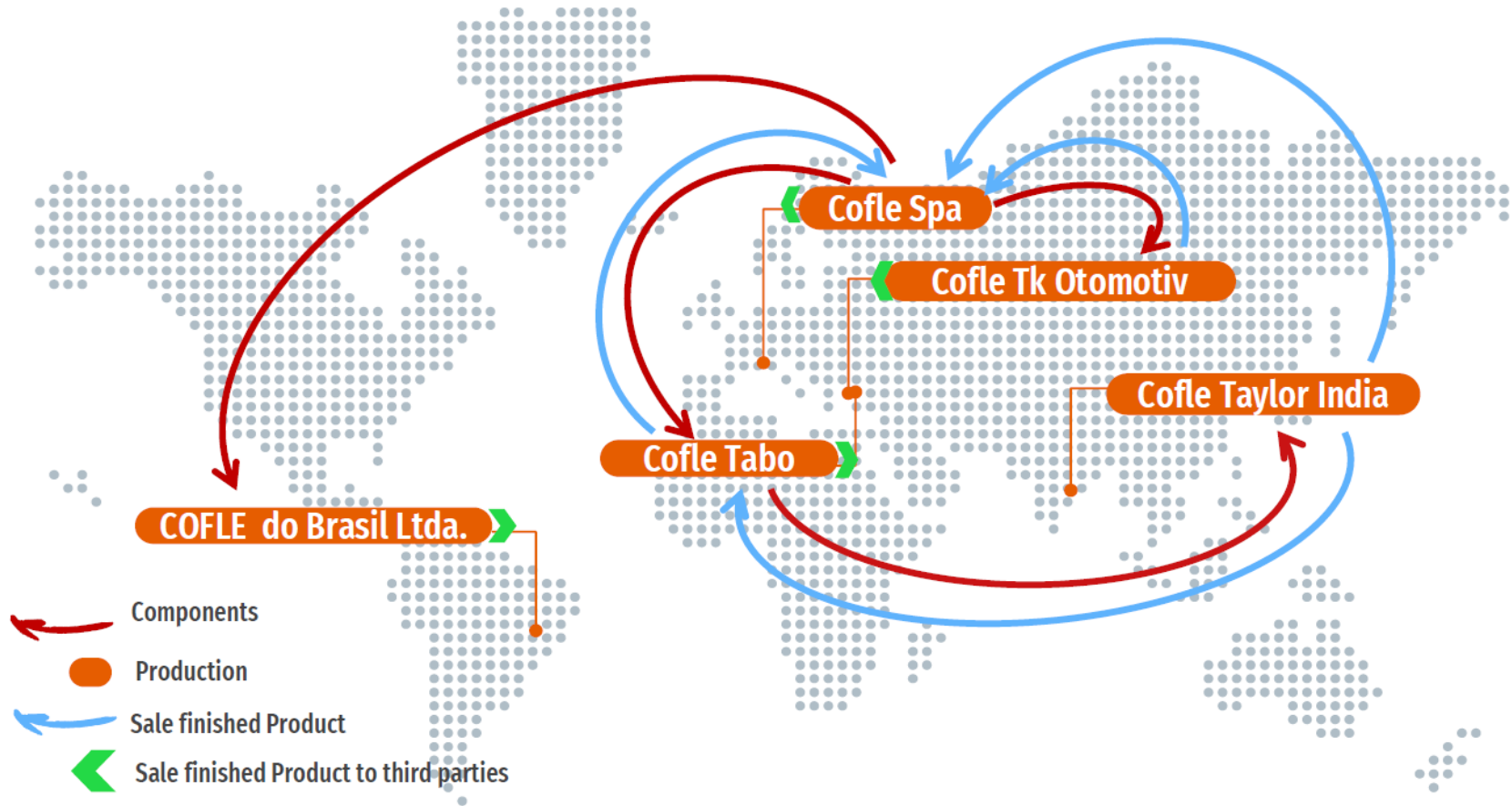

1

Global integrated facilities to meet multinational customers' needs centered on shifting from overstretched supply chain to **locally based suppliers**

2

Key competitive advantage by leveraging on **established local presence** especially in **Turkey** and **India** to lower production costs and boost market share

4 STATE OF ART CREDENTIALS - OE

A highly prestigious and diversified customer base all over the world



- 1 Long term relationship with Top Market Leaders in the world, ranging from CNH to AGCO and John Deere as undisputed proof of leadership. It usually takes at least 2 years to be included in the supplier list
- 2 Traditional niche share of revenues coming from luxury automotive brands (Ferrari & Maserati)
- 3 Traditional niche share of revenues coming from commercial light vehicles brands (IVECO)

STATE OF ART CREDENTIALS - IAM

From Top Aftermarket Manufacturers to Top Aftermarket distributors



BOSCH

TRW
Automotive



sbs
Automotive

**FEDERAL
MOGUL**



FTE
automotive



JP-Group a/s
AUTOMOTIVE



AKWEL

Metzger
Autoteile

**ALLIANCE
AUTOMOTIVE GROUP**

- 1 Long term relationship with Top Aftermarket Leaders in the world (Continental & Bosch)
- 2 Long term relationship with Top Aftermarket Distributors in the world (Federal Mogul & Unix)

6 FOCUS ON R&D

Innovation to anticipate next future trends

Commitment to launching disruptive solutions to stand out



2

R&D CENTER



28

PEOPLE EMPLOYED IN R&D ACTIVITIES



2

ENGINEERING CENTER



8

REGISTERED PATENTS IN THE LAST 5 YEARS ACROSS 5 COUNTRIES



1

DEDICATED OEM INNOVATION HUB

HOW WE INNOVATE IN COFLE

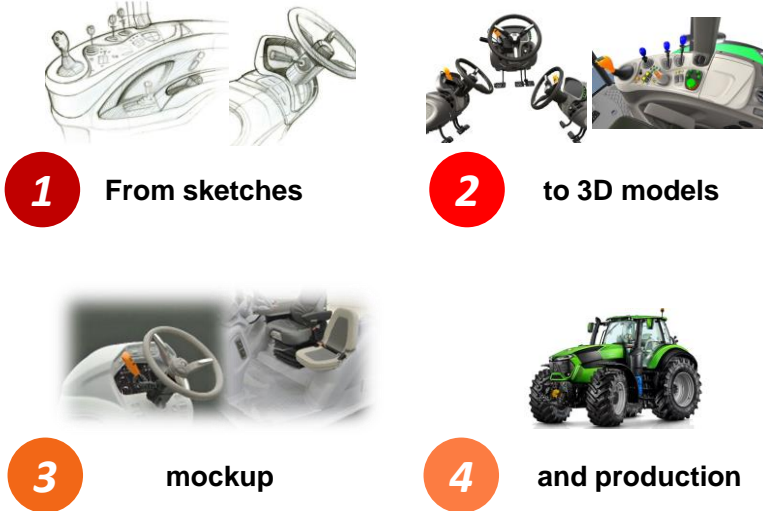

READY FOR NEXT AGRICULTURE CHAPTER

- Automation
- Precision Farming
- Artificial Intelligence



Tomorrow



In 20 years



Today



In 10 years



In 50 years



UPDATE

UPDATE

Cofle France s.a.s. - Bureau Commercial

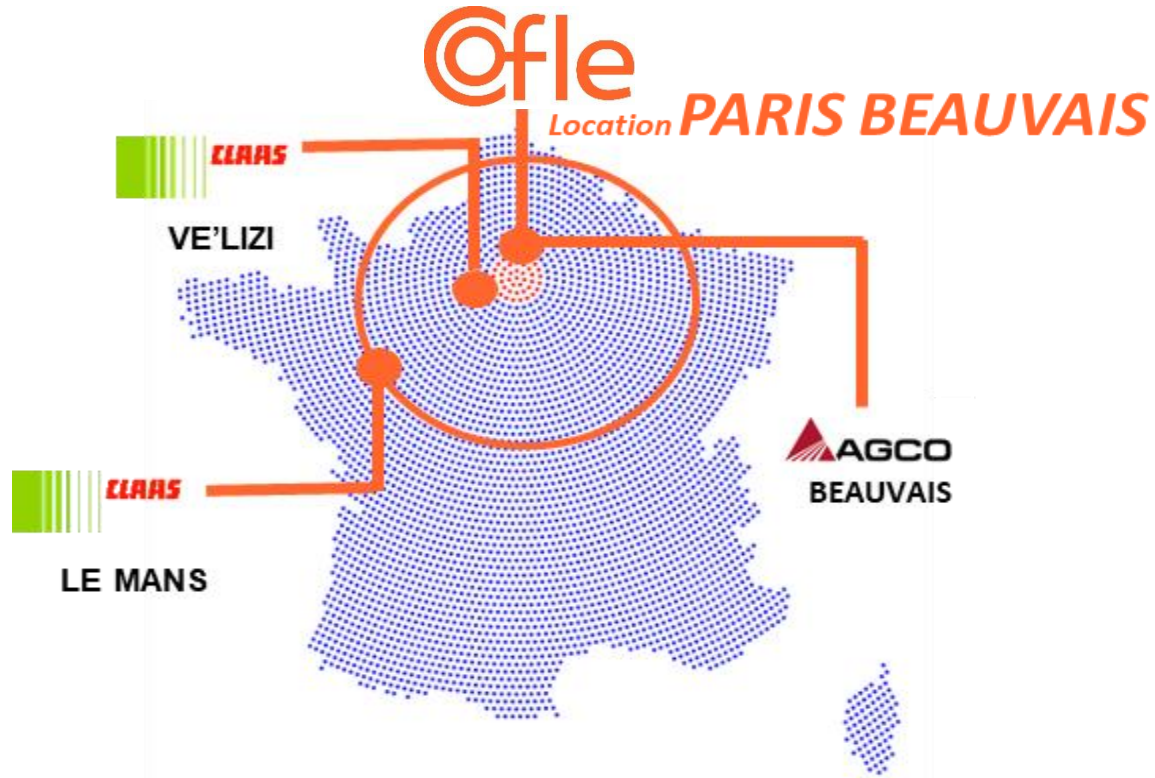

Cofle's aim is to have a direct presence in the French market, an area where Cofle operates since 1980s. From France the rationale is to intensify commercial activities in **Spain, Portugal, Maghreb and Benelux**, areas that present important potential in terms of prospects for our sector

The French subsidiary has recently entered into **two significant commercial agreements**. The first one has been forged with the second-largest European spare parts distribution group, which will resell Cofle's products through its international platform. The second agreement has been signed with a spare parts distributor that is part of a large industrial group in the automotive sector

OE NEW PROJECTS UPDATE

INEOS

GRENADIER



The agreement provides that, following the excellent results obtained in the first test phase and the second and final phase of testing in February 2022, the total value of production for Cofle in the two-year period 2023/2024 is equal to **5,5 million euros**

Cofle technology is aboard the new off-road Ineos Grenadier



Cofle provides **Transfer Case Manual Shifter and Cables**, which enables the unlocking of the differential to vary power distribution to each individual wheel, as well as the engagement and disengagement of low gears

OE NEW PROJECTS UPDATE

Off Road Products – Specific projects for two customers

Development of **innovative electronic products** that represent an upgrade of the control system to ride precision farming wave



OE NEW PROJECTS UPDATE

Off Road Products – Some examples of mechatronic & electronic applications

In the Turkish plant, a new production department has recently been added for the manufacturing of electronic components

The new department will be responsible for assembling PCBs and electronic boards designed in-house and produced using 'pick to place' machinery

The new area will be dedicated to the assembly of sensors, switches, and mechatronic systems such as manipulators and armrests

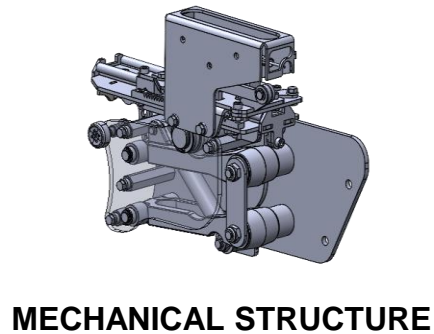
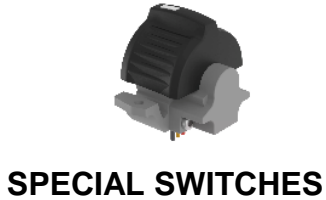

IAM NEW PRODUCTS UPDATE

All-In-House production to maintain high margins

BRAKE HOSES

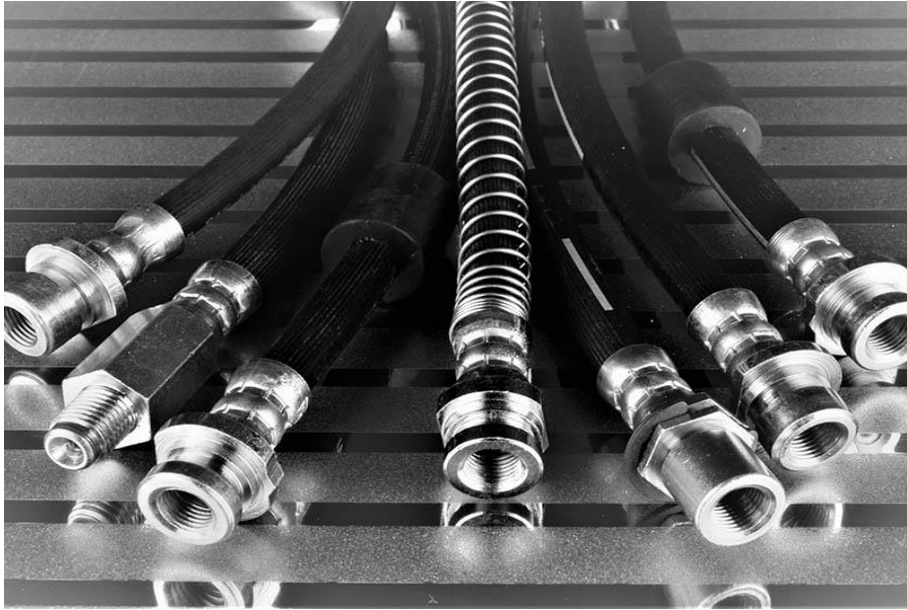

In 2021 there was a big increase brake hoses revenues: € 416 thousands.
Full Year 2022: € 585 thousands

EPB PROJECT

Sensors

Clutch position sender



Electromechanical parking brake button



Autohold button



Electromechanical parking control unit

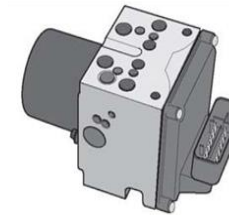
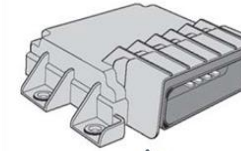

ABS control unit

Actuators

Left / Right brake EPB

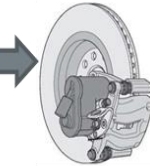

Electromechanical parking brake warning light



Brake system warning light



Electromechanical parking brake fault warning lamp



Autohold warning light



NEW LOGISTICS CENTER IN ITALY

Warehouse A

Warehouse B



Around **3.500 sq.m.** just in proximity of Autostrada A4, a few minutes from the Headquarters, between Milano and Bergamo.

Operational from **11/2023**. It will host the **OE Logistic Division**



SDG MAPPING

6 out of 17 SDGs have been considered primary to achieve before the end of 2024



- Start of the prevention project with free medical visits for employees in collaboration with LILT (Italian League for the Fight against Cancer)



- Increase in the share of female presence in the company



- Feasibility study for installation of geothermal plant
- 100% renewable energy target in Italy



- Study of new packaging to replace the use of plastic for all AM clients



- Purchase of GO certificates to increase the share of electricity from renewable sources
- Scope 3 greenhouse gas emission inventory and redefinition of reporting perimeter



- Adoption of the Organizational Model of Management and Control D.Lgs 231/01
- Study and inclusion of ESG goals in the remuneration systems of Managers

ESG PERFORMANCE

ENVIRONMENTAL

- **8,4%** total energy consumption per revenues (2021 vs. 2020)
- **44,7%** electricity from renewable sources [-29 t CO2e issued in 2021]
- **96%** raw materials used by recycling (Aluminium and Zamak) [-385 t CO2e issued in 2021]
- **40%** recycled component in packaging (wood and cardboard) [-53 t CO2e issued in 2021]
- **14,8%** total waste generated per revenues (2021 vs. 2020)
- **19,2%** direct and indirect greenhouse gas emissions (scope 1 and 2) per euro of revenues (2021 vs. 2020)

SOCIAL

- **100%** of employees on permanent contracts
- **41,5%** share of women on total employees
- **50%** recruitment of < 30 years
- **+5,7%** growth of employees (2022 vs 2020)
- **1** recorded accident only
- **0.04%** accident severity index
- Selection and evaluation of suppliers with environmental, ethical and social criteria

GOVERNANCE

- Code of Ethics
- Integrated Quality and Environment Management System in compliance with UNI EN ISO 9001 and 14001 standards
- Internal Dealing procedure
- Procedure for Inside Information and the Insider Registry
- Procedure for Related Party Transactions

FINANCIAL HIGHLIGHTS

GROUP SALES BY DIVISION – Update 1H 2023

Sales Breakdown by division
(FY 2021 – 2022)

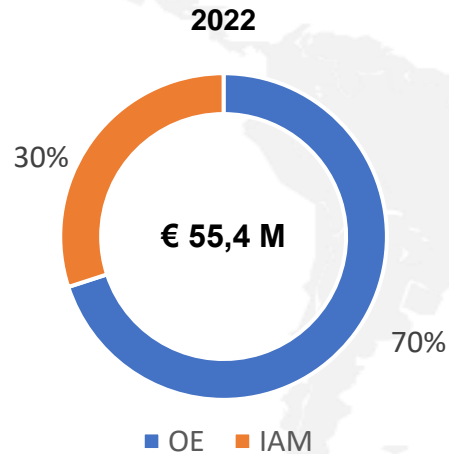
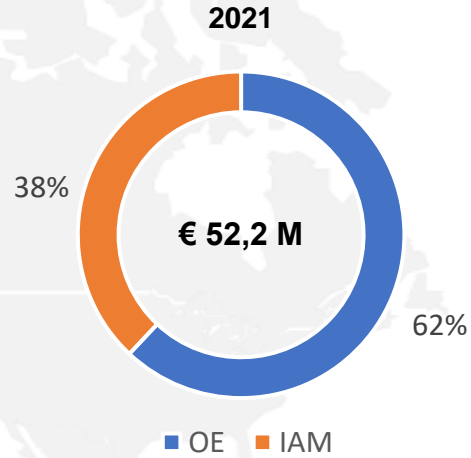

Sales Breakdown by division
(1H 2022 vs 1H 2023)

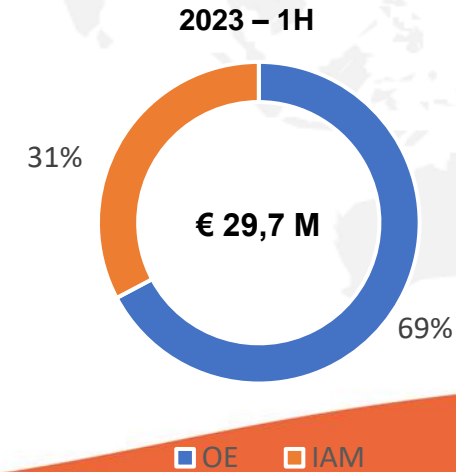
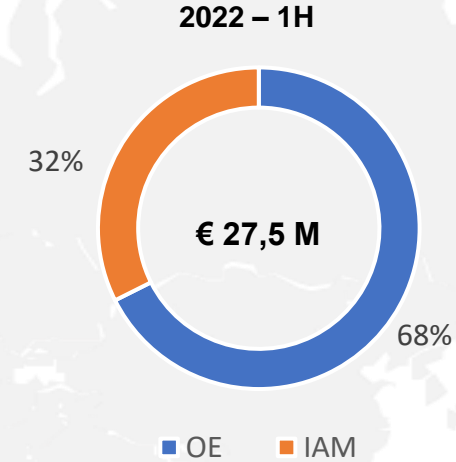

FINANCIAL HIGHLIGHTS

Cofle Total Revenues & Sales

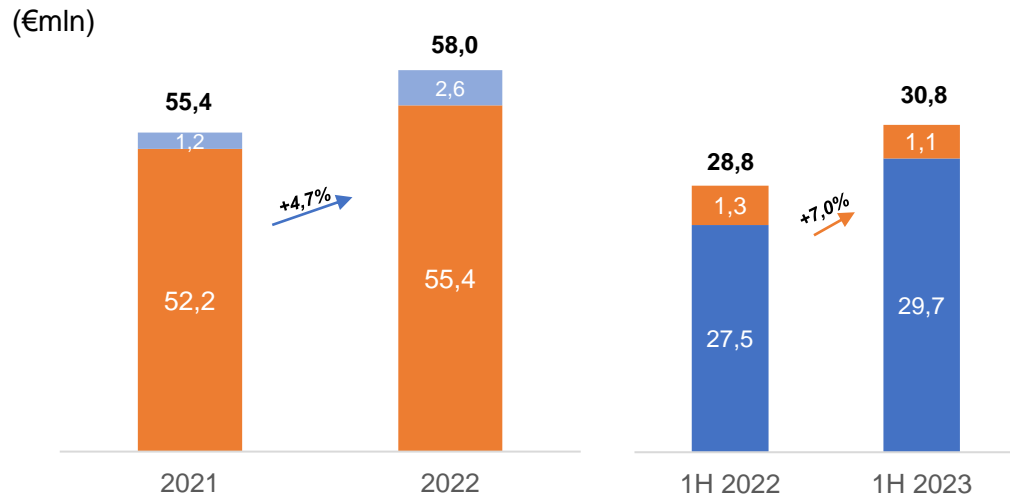

EBITDA IFRS 16 Adj. and EBITDA Margin

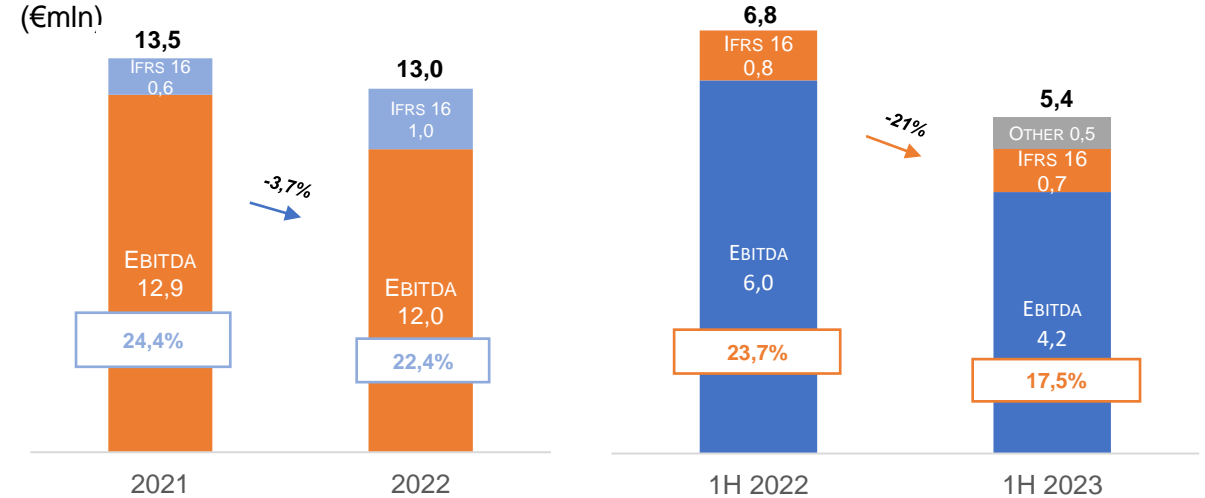

EBIT and EBIT Margin

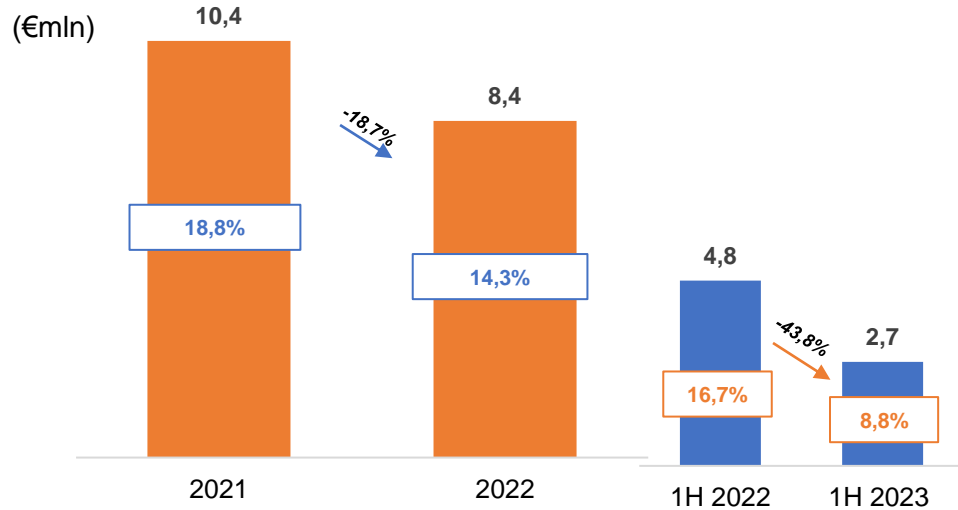

Net Income and Net Income Margin

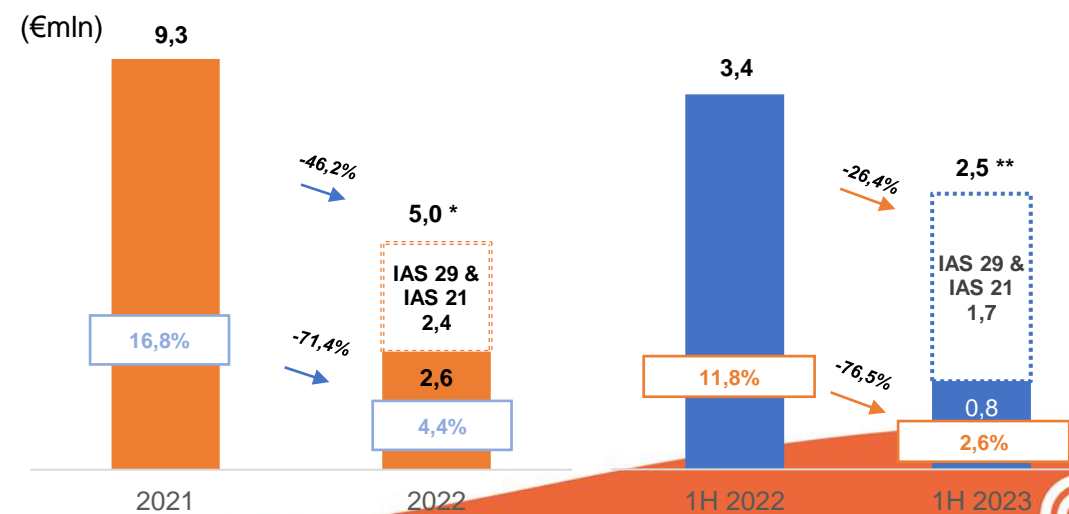

CONSOLIDATED NET WORKING CAPITAL

Net Working Capital Analysis

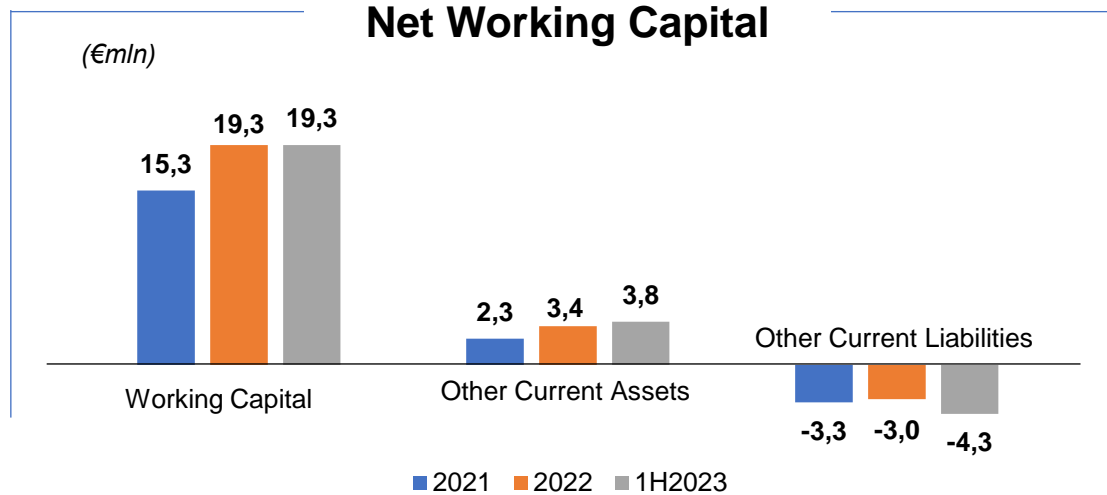

(€mln)

NWC 2021	NWC 2022	NWC 1H2023
14,4	19,6	18,8

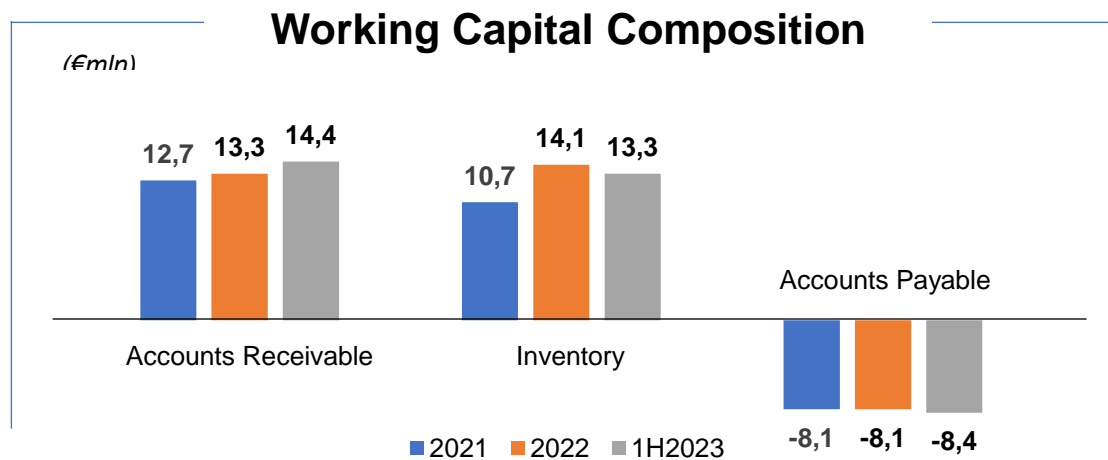

	2021	2022	1H2023
DSO	~83	~86	~85
DIO	~120	~140	~137
DPO	~88	~91	~83

FIXED ASSETS AND CAPEX

Tangible, Intangible and Financial Assets

Fixed Assets

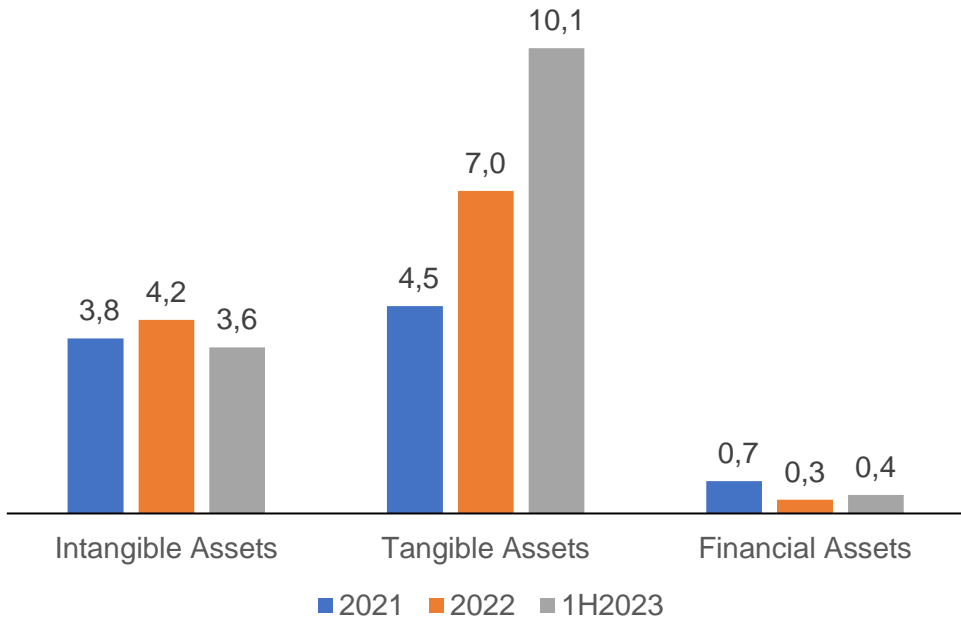

Consolidated Capex 2022

(€mIn)

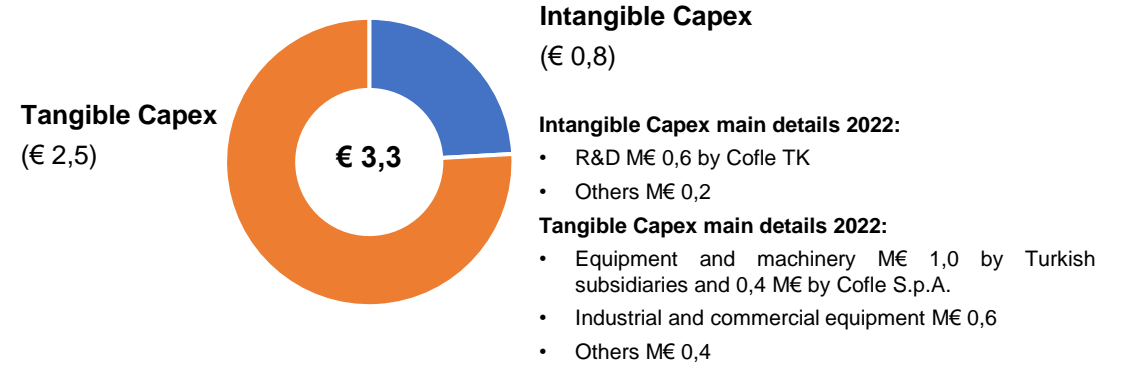

Consolidated Capex 1H2023

(€mIn)

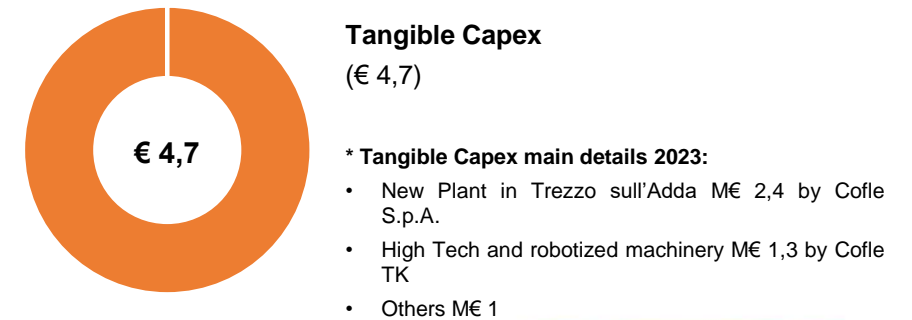

NET FINANCIAL POSITION FY 2021 - 1H 2023

NFP IFRS 16 FY 2019-2022

Composition of Net Financial Position

(€)	2021	1H 2022	2022	1H 2023
Long Term Financial Debts	9.348.695	7.867.844	10.301.703	7.384.983
Short Term Financial Debts	1.299.154	4.621.425	4.269.010	8.304.368
Cash and Cash Equivalents	-15.493.769	-13.509.892	-20.319.815	-17.376.552
Other Current Financial Assets	-	-	-190.960	-281.920
Shareholder Financial Receivable	429.900	-	-	-
Financial debts vs Parent Company	722.500	413.000	255.000	-
Other Financial Debts	58.870	429.900	4.883.811	5.301.922
Net Financial Position ITA GAAP ex Valdiporto	-3.634.650	-177.723	-801.251	3.332.801
Valdiporto Financial Receivable*	-600.000	-50.000	-	-
Net Financial Position ITA GAAP	-4.234.650	-227.723	-801.251	3.332.801
Ifrs 16 Adjustment	4.266.000	3.825.000	3.475.000	5.210.337
Net Financial Position IFRS 16	31.350	3.597.000	2.673.749	8.543.138

Financial Ratio – IFRS 16

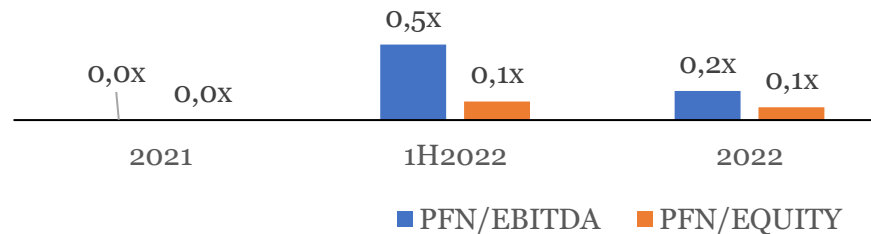

- Other Financial Debts include € 4.852.919 related to a Basket Bond issued in November 2022. Interest rate 5,06%, period end October 2028
- At 30/06/2023, NFP is equal to € 3,3 M.

CASH FLOW

Net Financial Position Bridge FY22 to 1H2023

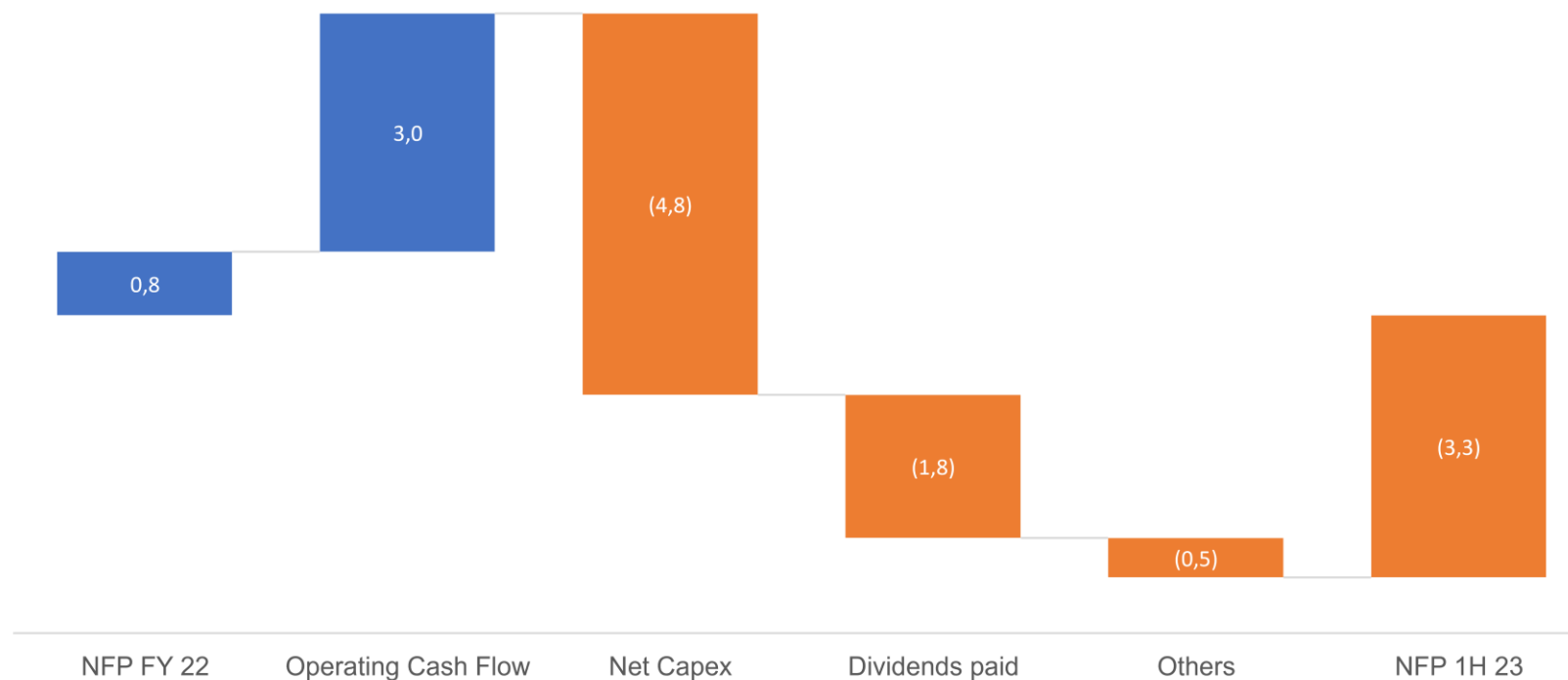

Cash Outflow of 4,1 M



WWW.COFLE.COM

investor@cofle.it
info@cofle.it

Headquarters

Via del Ghezzo 54

Trezzo sull'Adda (MI) Italy

+39 02920020201



Cofle